

SHARP TOP CHAIN

- 60-1, 60-2, 60-3, ST & SL Series
- 80-1, 80-2, 80-3, 80-4, 80-6, ST, PEP, & SL Series
- 100-1, 100-2, 100-3, 100-6, ST & SL Series
- 120-1, 120-2, ST & PEP Series

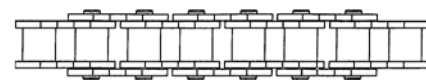
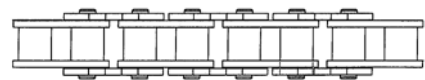

SHARPTOP

SHARPTOP "PEP"

Many other sizes available from stock

DOUBLE LENGTH INFEEED / SCANNING CHAIN, GUIDE RAIL & SPROCKETS



- High speed applications
- Accurate guiding systems
- Treated surfaces for extended wear life
- VC 200LR has grease fittings in each rivet

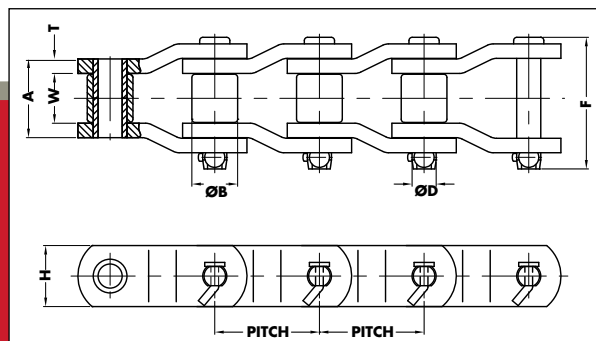

CONNEXUS CHAIN NO	PITCH	ULT STG/LB	D	W	T	A	H	B	F
VC50/VC50LR	3.067	110,000	0.75	1.56	0.38	2.31	2.25	1.62	3.94
P35B100A*	3.937	68,000	0.87	1.21	0.39	N/A	2.36	1.77	2.9
VC100 / VC100LR*	3.937	100,000	0.94	1.12	0.50	N/A	2.50	1.78	3.84
VC200/VC200LR	4.073	100,000	0.94	1.09	0.50	2.13	2.50	1.78	3.7
VC205/VC205LR	4.073	100,000	0.94	2.12	0.50	3.12	2.50	1.78	4.8
VC124N/VC124N-LR	4.073	100,000	0.94	1.25	0.50	2.25	2.50	1.75	3.84

* Straight sidebar chain
 Tabular dimensions and design are subject to change. Verifications is recommended as Connexus in continuously improving it's products.
 Dimensions are in inches, loads in lbs.

LANGLEY
BRITISH COLUMBIA

27474 Gloucester Way, Langley BC, Canada V4W 4A1
 † 604.882.1602 † 604.882.1603 toll free 1.800.324.1244

SAINT-NICOLAS
QUEBEC

11194 Chem. Industriel #108 Saint-Nicolas, QC G7A 1B1
 † 418.834.5116 † 418.834.5901 toll free 1.888.650.6090

ATLANTA
GEORGIA

3411 Novis Pointe, Acworth, GA, USA 30101
 † 678.797.0777 † 678.797.5554 toll free 1.877.941.1500

Printed in Canada 924



INDUSTRIES INC

Chain & Industrial Manufactured Solutions

LEAF CHAIN

WELDED STEEL CHAIN

WELDED STEEL
DRAG CHAIN

TRIMMER CHAIN

MALLEABLE CHAIN

COMBINATION CHAIN

SHARP TOP CHAIN

NON-MARKING CHAIN

DOUBLE LENGTH CHAIN

ROLLER CHAIN

ROLLER CHAIN
ATTACHMENTS

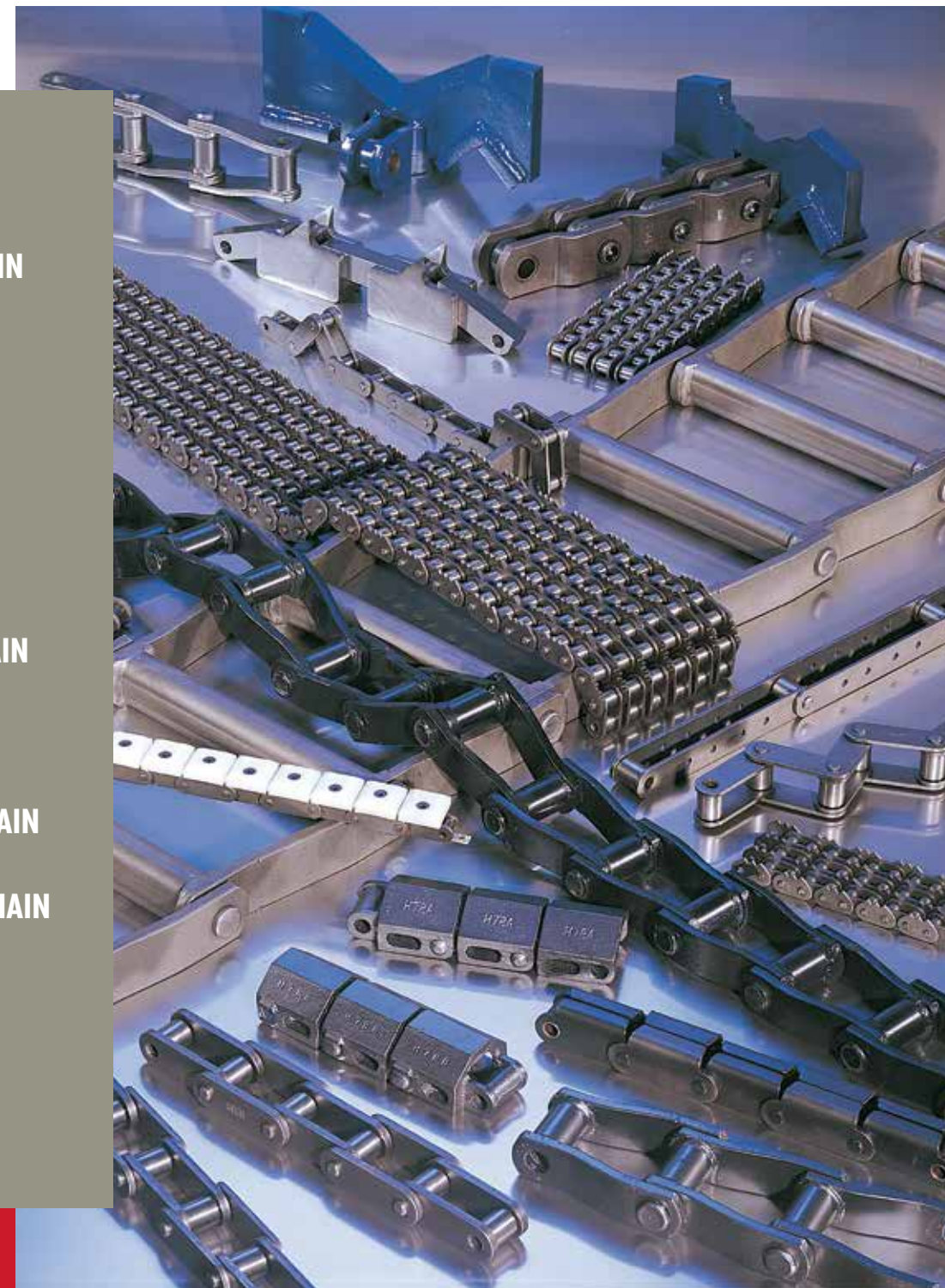

www.connexusindustries.com

TRIMMER CHAIN

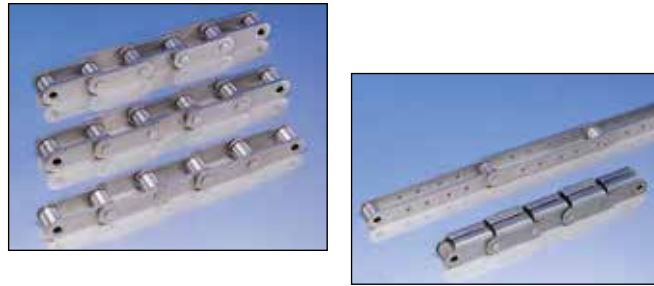
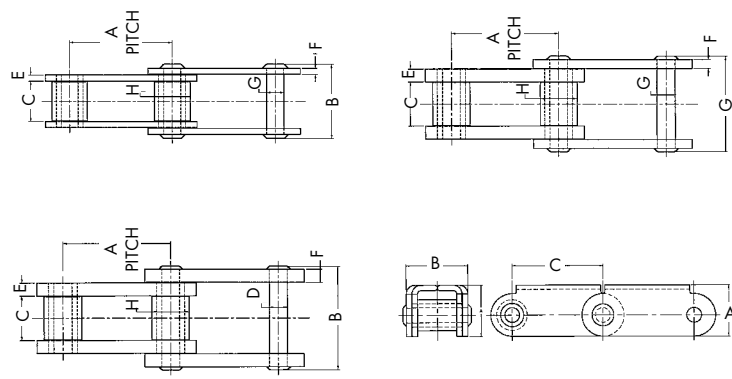

CHAIN	A	B	C
81X ROOFTOP	1 1/2	1 13/16	2.609

CHAIN	PITCH	LINKS/FT	WT/FT LBS	B	C	E	F	G	H
81X	2.609	4.6	2.6	1.895	1 1/16	5/32	5/32	7/16	29/32
81X H	2.609	4.6	3.9	2.325	1 1/16	5/16	7/32	7/16	29/32
81X XHD	2.609	4.6	4.6	2.510	1 1/16	5/16	5/16	7/16	29/32
81X ROOFTOP	2.609	4.6	6.0	1 13/16	1 1/16	5/32	5/32	7/16	29/32
*3939 G4	8.000	1.5	1.62	1.895	1 1/16	5/32	5/32	7/16	29/32

* 4 holes per sidebar 9/32 diameter @ 1 1/2" & 4" centers

MALLEABLE & COMBINATION CHAIN

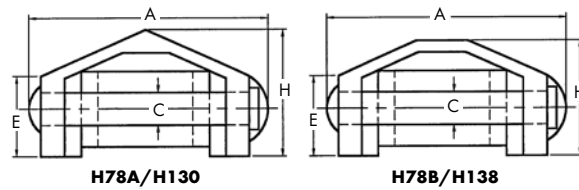
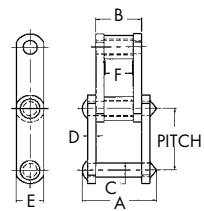

CHAIN	PITCH	LINKS/FT	WT/FT LBS	A	B	C	D	E	H
H78	2.609	4.6	4.3	3 3/8	-	1/2	-	11/16	1 11/16
H78 A/B	2.609	4.6	5.6/6.2	3 3/8	-	1/2	-	11/16	1 11/16
H130/138	4.000	3	5.3/5.9	3 3/8	-	1/2	-	17/64	1 11/16
C55	1.630	7.4	2.0	1.813	17/32	3/8	7/32	3/4	3/4
C188	2.609	4.6	3.5	2 7/8	19/16	1/2	1/4	1 1/8	
C131	3.075	3.9	6.7	3 3/8	2	5/8	3/8	1 1/2	1 1/81 1/8
C102B	4.000	3	6.4	4 9/16	25/32	5/8	3/8	1 1/2	1 1/8
C55A/B	4.000	7.4	2.5	1.813	17/32	3/8	7/32	23/32	1 5/8

CONVEYOR CHAIN "H" SERIES

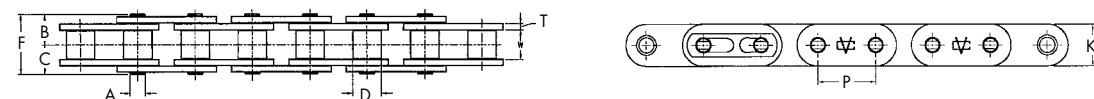

CHAIN	PITCH	ULT STG	LINKS/FT	WT/FT LBS	F - RIV	F - COTT	A	B	C	D	K	W	T
C2060H	1.5	12,300	8	1.03	1.130	1.221	.234	.573	.652	.469	.677	.500	.125
C2080H	2.0	20,200	6	1.65	1.398	1.528	.312	.720	.823	.625	.890	.625	.156
C2100H	2.5	30,800	4.8	2.38	1.662	1.800	.375	.858	.965	.750	1.126	.750	.187

WELDED STEEL CHAIN

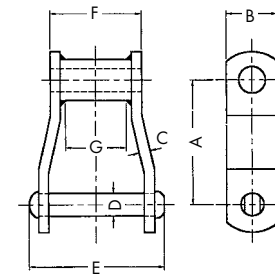

- WH chains are fully heat treated
- WR chains have heat treated rivets



CHAIN	A	B	C	D	E	F	G	ULT STG/LB	LINKS/FT	WT/FT LBS
WH78	2.609	1 1/4*	1/4	1/2	3	2	1	32,800	4.6	4.1
WH78XHD	2.640	1 1/4	3/8	9/16	3 9/32	2	1	35,800	4.5	6.3
WH82	3.075	1 1/4	1/4	9/16	3 5/16	2 1/4	1 3/8	35,900	3.9	4.7
WH82XHD	3.075	1 1/2	3/8	3/4	3 13/16	2 3/8	1 1/8	57,000	3.9	8.4
WH124	4.000	1 1/2	3/8	3/4	4 1/4	2 13/16	1 1/2	56,200	3	8
WH111	4.760	1 3/4	3/8	3/4	4 13/16	3 3/8	1 7/8	57,000	2.5	8.6
WH106	6.000	1 1/2	3/8	3/4	4 1/4	2 13/16	1 1/2	59,000	2	6.5
WH106XHD	6.050	2	1/2	1	4 7/8	3	1 1/2	121,000	2	11.5
WH124XHD	4.050	2	1/2	1	4 7/8	3	1 1/2	120,000	3	14.5
WH132	6.050	2	1/2	1	6 1/4	4 27/64	3 1/8	85,000	2	13.5
WH132XHD	6.050	2	5/8	1	6 3/4	4 11/16	3 1/8	122,000	2	15.9
WH150	6.050	2 1/2	1/2	1	6 1/4	4 27/64	3 1/8	122,000	2	15.5
WH150	6.050	2 1/2	5/8	1	6 3/4	4 11/16	3 1/8	124,000	2	18
WH157	6.050	2 1/2	5/8	1 1/8	6 3/4	4 5/8	3 1/8	175,000	2	20

* 1 1/8 USA

WELDED STEEL DRAG CHAIN

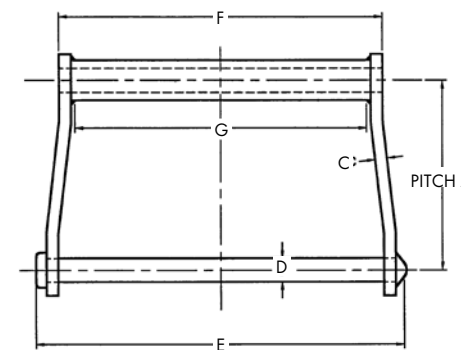

- WDH chains are fully heat treated
- WDR chains have heat treated rivets



CHAIN	A	B	C	D	E	F	G	ULT STG/LB	LINKS/FT	WT/FT LBS
WDH102	5.000	1 1/2	3/8	3/4	9 1/4	7 3/4	6 3/8	78,000	2.4	12
WDH104	6.000	1 1/2	3/8	3/4	6 3/4	5 3/8	4 1/8	54,000	2	8.6
WDH110	6.000	1 1/2	3/8	3/4	11 3/4	10 1/4	9	54,000	2	12
WDH112	8.000	1 1/2	3/8	3/4	11 3/4	10 1/4	9	54,000	1.5	10
WDH116	8.000	1 3/4	3/8	3/4	15 1/2	14 1/8	13	54,000	1.5	12.9
WDH120	6.000	2	1/2	7/8 - 1	12	10 1/4	8 3/4	85,000	2	19
WDH122	8.000	2	1/2	7/8 - 1	12	10 1/4	8 3/4	85,000	1.5	16
WDH480	8.000	2	1/2	7/8 - 1	14 1/2	12 3/4	11	85,000	1.5	17.2
WDH118	8.000	2	1/2	7/8 - 1	16 5/8	14 7/8	13 1/4	85,000	1.5	19.5